

SLIDING DOOR DRIVE UNIT

SL 45



The powerful drive system for large and heavy-weight applications

- Single-leaf and bi-parting sliding doors
- Two- and four-leaf telescopic sliding doors
- For a max. door leaf weight of 1 x 240 kg and 2 x 240 kg
- With side door panel, glazed overhead panel and protection leaf
- PSXP, PST profile systems and leaves supplied by others
- Emergency-exit function (redundant option)
- Gilgen CAN-Bus sensors as well as sensors supplied by others
- Battery BATPA
- Carlock running carriage locking integrated in the drive mechanism (standard and redundant configuration)
- FLUVERI multi-point locking automatic / manual
- Door and lock monitoring TUWE VdS
- Air curtain control
- Control pillar for a simple arrangement of all the control elements directly next to the clear opening
- KIT compatible drive concept
- TÜV-tested for conformity with corresponding standards (e.g. EN 16005, DIN 18650)

Profile systems

The SL 45 drive system is compatible with our profile systems (PSXP and PST) and fits with any metal structure design.

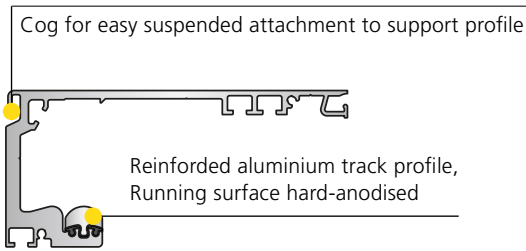

SL 45-S - standard (PSXP)
With side panel and support profile

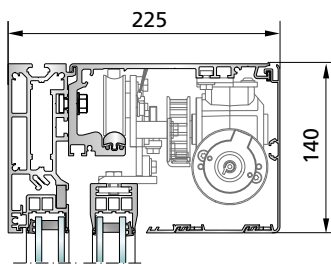

SL 45-S - standard (PSXP)
Without side panel,
without support profile

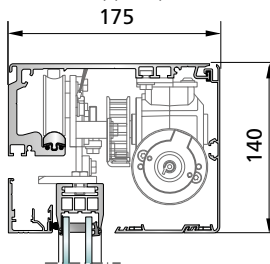

SL 45-T - standard (PSXP)
With side panel, without support profile

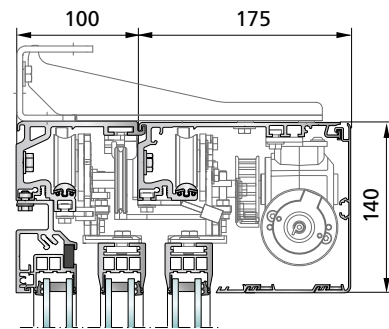

SL 45-S - thermally insulated (PST)
With side panel and support profile

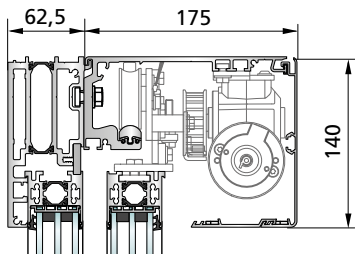

SL 45-S - thermally insulated (PST)
Without side panel and
support profile

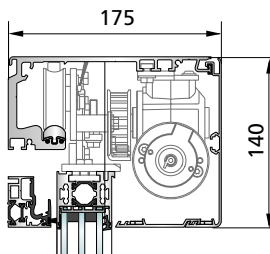

SL 45-T - thermally insulated (PST)
With side panel and support profile

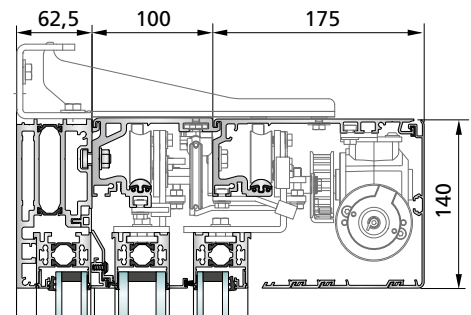

SL 45-S - leaf by others with connection
profile, door leaf width up to 50 mm

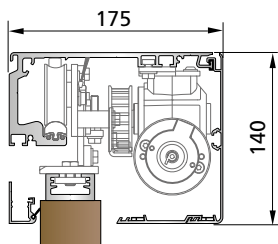

SL 45-S - leaf by others with connection
profile
Door leaf width 50 - 90 mm

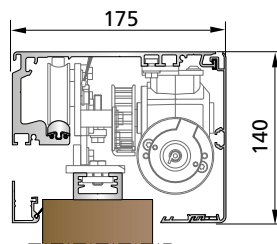

SL 45-S - leaf supplied by others
Door leaf width up to 50 mm

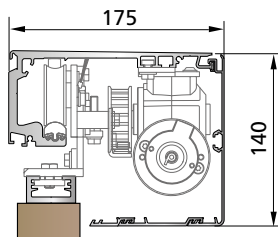

SL 45-S - leaf supplied by others
Door leaf width 50 - 90 mm

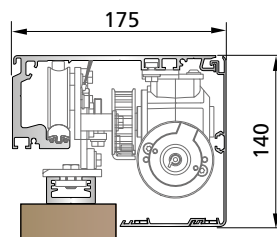

SL 45-S - leaf supplied by others
Door leaf width 44 mm

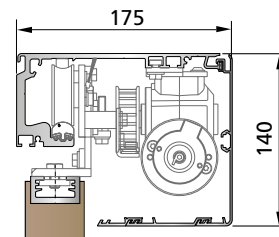

Standard profile system (PSXP)

- Single-leaf and bi-parting sliding doors
- With side door panel, protection leaf
- Full length bottom rail, with or without drainage / fixed point guide
- Emergency-exit function (redundant)
- RC2 / RC3 break-in prevention design
- Certified overall system (EN 16361)
- Vertical interlocking
- 6 - 24 mm glass

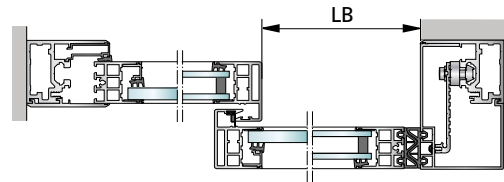
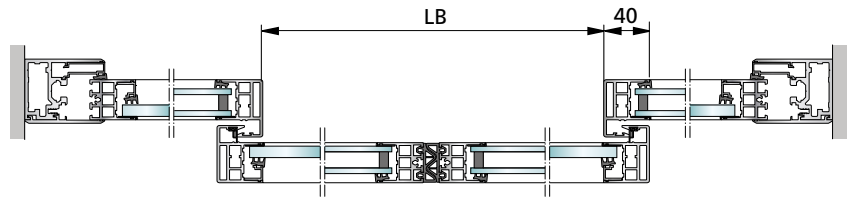

Thermally insulated profile system (PST)

- Single-leaf and bi-parting sliding doors
- High-level thermal insulation / low „U“ value
- With side door panel, protection leaf
- Full length bottom rail, with or without drainage / fixed point guide
- Emergency-exit function (redundant)
- Certified overall system (EN 16361)
- RC2 / RC3 break-in prevention design
- 24 - 38 mm glass, double- or triple-glazed

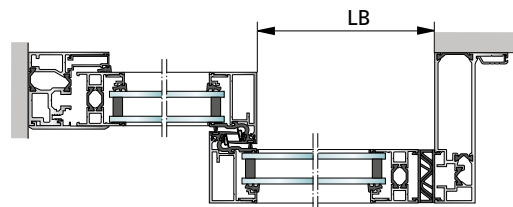
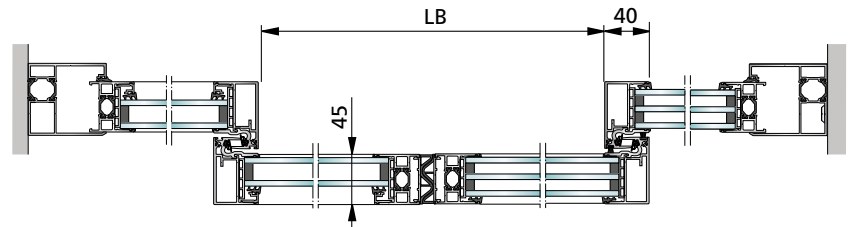

Leaves supplied by others

- Single-leaf and bi-parting sliding doors
- With connection profile and central sealing
- Full length bottom rail / fixed point guide
- Emergency-exit function (redundant)

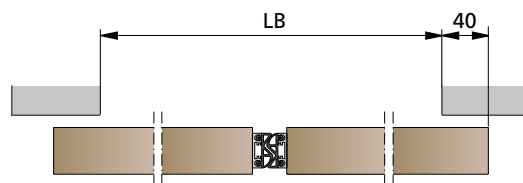
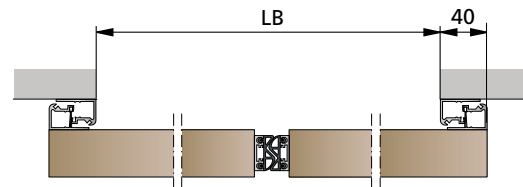

Gilgen SL 45 – a powerful performance

Simple, reliable and functional - SL 45

- 240 kg per sliding door leaf (Telescopic 2 x 170 kg, 4 x 120 kg)
- The perfect addition to the SL 35
- Clear width 3000 mm / clear height 3000 mm
- Mains supply 100-240 VAC (+10%/-15%), 50/60 Hz
- Max. door leaf speed 0.8 m/s (adjustable)
- Hold-open time, day 0-60 s
- Protection type IP23
- Ambient temperature -15 ... +50 °C
- Redundancy conforms to Performance Level „d“ in accordance with EN 13849-1



Low-noise design with optimised running carriage configuration

- Running carriage designed to match performance
- Damped carrying roller system for quiet operation and particularly heavy weight door leaves
- Easy adjustment of counter-pressure roller
- Easy door leaf adjustment



Automatic opening combines convenience with personal safety

- Integrated CAN-bus sensors guarantee maximum personal safety and reliable functioning of the door
- Compatible with sensors supplied by others
- Emergency-exit function conforming to EN 16005 / DIN 18650



Safety and security – this future-oriented system offers security, while protecting property and preventing break-ins

- Overall solutions tested to EN 16005 standards, with emergency-exit (redundant)
- Break-in prevention functions (RC2 / RC3)
- Secure manual unlocking mechanism (inside and outside)



Control Panel – simple and intuitive

- Easy-to-use touchscreen display
- AUTOMATIC-OPEN-EXIT-NIGHT-MANUAL-reduced opening
- Information on the operating state

